

2012

Studies and Survey Report Solid Waste Quantities and Characteristics in Seven Urban Centers of Gilgit-Baltistan (GB)



Gilgit-Baltistan Environmental Protection Agency

GB-EPA Khomar Cant near FPSC Office, Gilgit

Phone No. 05811-920679 Fax No. 05811-920676





Gilgit Baltistan Environmental Protection Agency (GB-EPA),
Government of Gilgit Baltistan

Copyright:

Gilgit Baltistan Environmental Protection Agency (GB-EPA),
Government of Gilgit Baltistan

Citation is encouraged. Reproduction and/or translation of this publication for educational or other non-commercial purposes is authorised without prior written permission from Environmental Protection Agency (EPA), Gilgit Baltistan, provided the source is fully acknowledged.

Reproduction of this publication for resale or other commercial purposes is prohibited without prior written permission from Environmental Protection Agency (EPA), Gilgit Baltistan.

Resource Persons:

Shehzad Hasan Shigri (Director GB-EPA)
Khadim Hussain (Assistant Director R&D/NEQS)

Photography:

Khadim Hussain, Assistant Director GB-EPA
Akbar Shah, GIS Exp
Waseem Samad Khan
Imran Shah

Designed by:

Essential Solutions (Pvt) Ltd.

Available From:

Gilgit Baltistan Environmental Protection Agency (GB-EPA),
Government of Gilgit Baltistan

CONTENTS

List of Tables and Figures	iv
List of Tables	iv
List of Figures.....	iv
1. Introduction.....	1
1.1 Scope and Objectives	2
1.2 Scope of Services.....	2
2. Background.....	4
2.1 Geographic Location.....	4
2.2 Ecological Importance	4
2.3 Administrative Setup.....	4
2.4 Demographic Details	5
2.5 Climatic Conditions.....	5
2.6 Ecological Zones	5
2.7 Land Use Pattern	5
2.8 Environmental Concerns	5
3. Methodology	7
3.1 Tools for Assessment.....	7
3.1.1 Check List.....	7
3.1.2 Questionnaire Survey	7
3.1.3 Focus Group Discussion.....	7
3.1.4 Field Observation.....	8
3.1.5 Secondary Data Collection and Review	8
3.1.6 Documentation Information	8
3.1.7 Report Compilation and Preparation	8
4. Findings/ Results.....	9
4.1 Domestic Solid Waste.....	9
4.1.1 Gilgit.....	9
4.1.2 Skardu	10
4.1.3 Khaplu.....	10

4.1.4	Gahkuch.....	10
4.1.5	Astore	10
4.1.6	Chilas	10
4.1.7	Hunza -Nagar	10
4.2	Commercial Waste	11
4.3	Special Waste	12
4.4	Industrial.....	13
4.5	Slaughter Waste	14
4.5.1	Gilgit.....	14
4.5.2	Skardu.....	15
4.5.3	Hunza-Nagar	15
4.5.4	Astore	15
4.5.5	Khaplu.....	15
4.5.6	Chilas	16
4.5.7	Ghizer.....	16
4.6	Auto Mobile Workshops.....	16
4.7	Animal Dung	17
4.8	Construction and Demolition Waste	17
4.9	Seasonal Trends of Waste Generation and Utilization.....	18
4.10	Collection and Disposal System.....	18
4.10.1	Primary Collection	19
4.10.2	Secondary Collection	19
4.11	Transfer and Transport.....	21
4.11.1	Gilgit.....	21
4.11.2	Skardu	21
4.11.3	Chilas	21
4.11.4	Ghizer.....	22
4.11.5	Transfer and Transport in Astore	22
4.11.6	Hunza-Nagar	22
4.11.7	Khaplu.....	22
4.12	Final Disposal.....	23
4.13	Solid waste segregation.....	23
4.13.1	Recovery of Reusable and Recyclable Material.....	23
4.14	Administrative and Institutional Mechanism	25

4.14.1	Administrative Mechanism.....	25
4.15	Financial Mechanism.....	27
4.16	Capacity Evaluation.....	27
4.16.1	Equipment and Machinery Capacity.....	27
4.17	Efficiency of Waste Collection and Dumping.....	28
4.18	Short Coming.....	29
4.18.1	Collection Efficiency.....	29
4.18.2	Street Side Heaps/Filth Depots.....	29
4.18.3	Hand Carts.....	30
4.18.4	Tractor Trolleys and Open Body Trucks.....	30
4.18.5	Open Dumping.....	31
5.	The Need to Adapt Western Technologies and Management Systems/ Recommendations.....	32
5.1	Waste Management Techniques.....	32
5.2	Landfill.....	32
5.3	Incineration.....	32
5.4	Volume Reduction.....	33
5.5	Compaction.....	33
5.6	Shearing.....	33
5.7	Clipping.....	33
5.8	Grinding.....	33
5.9	Resource Recovery Techniques.....	34
5.10	Reuse.....	34
5.11	Recycling.....	34
5.12	Composting and Digestion.....	35
5.13	Incineration, Paralysis and Gasification.....	35
	References.....	a

LIST OF TABLES AND FIGURES

LIST OF TABLES

Table 1.1: Current Municipal Solid Waste Generated in Urban Areas.....	1
Table 2.1: Administrative Division of Gilgit-Baltistan.....	4
Table 4.1: Solid Waste Management System, All Cities at a Glance	20
Table 4.2: District-wise Number of Vehicles, with Waste Lifting Capacity and Condition.....	22
Table 4.3: City Wise Dump Sites.....	23
Table 4.4: Recyclable Items in Municipal Waste of Gilgit-Baltistan	24
Table 4.5: Available Staff for Solid Waste Management in Gilgit-Baltistan Urban Centers....	26
Table 4.6: Budget Details for Solid Waste in 2009-10 (Million Rupees).....	27
Table 4.7: Equipment and Machinery Capacity.....	27
Table 4.8: Dumping Efficiency in Kilograms	28
Table 4.9: Dumping Efficiency in Percentage	29

LIST OF FIGURES

Figure 2.1: Map of Seven Major Towns of Gilgit-Baltistan.....	6
Figure 4.1: City Wise Composition of Solid Waste	11
Figure 4.2: City Wise Ordinary Commercial Waste (Kgs)	12
Figure 4.3: City Wise Industrial and Commercial Special Waste (Kgs).....	13
Figure 4.4: Recyclable and Reusable Domestic Solid Waste (Tons).....	24
Figure 4.5: Industrial/Commercial Waste Recovery and Disposal (Tons)	25
Figure 4.6: The Municipal Committee Organogram.....	26
Figure 4.7: Modified Hand Cart	30

1. INTRODUCTION

The Management dilemma of Solid Wastes (SW) has been recognized and tackled seriously worldwide. However, in developing countries the problem is still hindered by social and economic predicaments and priorities. In Gilgit-Baltistan, the generation of solid wastes has become an increasingly important environmental issue over the last decade, due to the escalating growth in populations and the changing life style, leading to new trends of unsustainable consumption patterns concomitant with an increase in wastes production. Such increases in solid wastes generation concurrent with shifting characteristics pose numerous questions concerning the adequacy of conventional wastes management systems, and their associated environmental, economic and societal implications.

In Gilgit-Baltistan due to the unavailability of any proper Solid Waste Management, sanitation and sewerage system, all Municipalities generating heaps of the solid waste in front of the Municipal Claims of Cleanliness. As a result the region is facing spread of epidemics, aesthetic pollution, water contamination, air pollution and soil pollution due to Solid waste generation and accumulation. Solid Waste Management in major urban centers of Gilgit-Baltistan remains an issue of concern for the masses and government alike. During the last several decades, huge migration occurred from rural to urban areas that induce huge population explosion with ten times increase during last decade. The last census conducted in 1998 revealed that the Gilgit-Baltistan Population was 0.884 million, however the latest estimates of Planning & Development Department conducted in 2007 suggests that it increased to 1.1 million and that approximately 14% of the population is urban centers . The population growth rate in GB is 2.56% as compared to the national average which is 1.8%. The male to female population ratio is 52:48 respectively. The region is sparsely populated as is evident from population density figures that 15 people per Square Kilometer area.

Table 1.1: Current Municipal Solid Waste Generated in Urban Areas

District	Urban area	Population	MSW generation (In Tons @ 0.4 kg per person/day)
Gilgit	Gilgit City	56701	23
Ghizer	Gahkuch city	10142	4
Ghanche	Khaplu city	12883	5
Skardu	Skardu city	26023	10
Diامر	Chilas city	16575	7

Solid waste has serious consequences on human health, soil chemistry, bird's, ground water and surface water, drainage system, atmosphere, worker health and surrounding population near dumping sites. The impacts of the solid have been increased from last one decade because of emerging population in urban centers of the Gilgit-Baltistan in general and Gilgit and Skardu in particular.

This background paper on Urban Environment is prepared by Government of Gilgit-Baltistan with assistance of IUCN providing baseline information on solid waste generation. Keeping in view of current environmental issues especially poor management of solid waste in the major urban centers of Gilgit-Baltistan, the GB-EPA has taken initiatives for quick action to improve the existing systems. In order to collect the base line data on solid waste management and existing handling practices, a comprehensive study "Studies and surveys for solid waste quantities and characteristics in seven urban of Gilgit-Baltistan".

Keeping in view of current environmental issues especially poor management of solid waste in the major cities of Gilgit Baltistan mainly Gilgit and Skardu, the GB-EPA has taken initiatives for quick action to improve the existing systems. This study will provide baseline data to design an appropriate system with realistic approach. This report deals with the Solid Waste Management System for the seven urban cities of Gilgit Baltistan, highlighting the existing solid waste management system along with the formulation of recommendations for improvements in the existing system, strategies and landfill options.

1.1 SCOPE AND OBJECTIVES

Scope of the project was assessment of solid waste, evaluation of existing solid waste management system and to suggest appropriate recommendations for integrated solid waste management system for effective solid waste management.

1.2 SCOPE OF SERVICES

The scope of services included but not limited to the following functions while implementing the project.

- General information through literature survey and physical surveys, municipal waste generation
- Estimation of future population with reference to its effect on municipal solid waste generation rate
- Quantitative and qualitative analysis of municipal waste generated in the Project Area

The present study “Air and Noise Pollution Monitoring in Urban Centres of GB” is an integral part of a GBEPA project titled “Strengthening of Laboratory and Baseline Studies for Environmental Parameters in GB”. Government of Gilgit-Baltistan allocated funds for this project through local ADP.

Gilgit-Baltistan Environmental Protection Agency (GB-EPA), investigated selected parameters on Indoor Air Quality and Stack Emissions from wood and other burning material used in stoves at household level. For this purpose samples were collected from selected household in seven districts of Gilgit-Baltistan. SGS Pakistan has provided the technical assistance to GBEPA to conduct this study.

The rationale is to investigate the level of Indoor air pollution levels at existing settings. It is quantitative data collected during the study and it will be used to devise an indoor mitigation strategy for reduction of in house air pollution due to fossil fuel pollutants. The report documents the finding of the indoor air quality survey conducted at technically selected locations of Gilgit-Baltistan region.

2. BACKGROUND

2.1 GEOGRAPHIC LOCATION

The Gilgit-Baltistan (GB) of Pakistan is located at 35⁰-37'N and 72⁰-75'E encompasses about 72,696 sq km area and provides home to a human population of nearly 1.8 million people (PCO 2008). Gilgit-Baltistan is transitional between south Asia and central Asia and bordering China in north, Afghanistan in west and India in east.

2.2 ECOLOGICAL IMPORTANCE

The Karakorum, Hindu Kush, Himalayan (KHKH) Mountains in the Gilgit-Baltistan; are home to a variety of ecosystems like glaciers, high altitude lakes, forests, pastures, agricultural lands and rivers, which provide high quality fresh water, food staples, medicines and other livelihoods to thousands of people living both up and downstream. There are about 5218 glaciers identified in the Karakorum Hindu Kush region, 2420 glacial lakes, 19 protected areas and three major Rivers, including River Indus one of the nine largest river systems in Asia.

These mountain ecosystems are also rich in highly diverse and endemic biological resources. Deosai National Park harbors enormous diversity of aromatic flora, Khunjerab National Park is one of the biodiversity hotspots in the cold desert eco-region of Pakistan and Central Karakorum National Park is famous for its unique peaks and endemic biodiversity.

2.3 ADMINISTRATIVE SETUP

Gilgit-Baltistan previously called Northern Areas has three divisions i.e. Gilgit, Baltistan and Diamer and divided into seven districts; includes Gilgit, Diamer, Hunza- Nagar, Ghizer, Astore, Baltistan and Ghanche. Each of these districts has been further divided into sub divisions.

Table 2.1: Administrative Division of Gilgit-Baltistan

Division	District	Area (km ²)	Headquarter
Gilgit	Gilgit	39,300	Gilgit
	Hunza-Nagar	-	-
	Ghizer	9,635	Gahkuch

Division	District	Area (km ²)	Headquarter
Baltistan	Skardu	18,000	Skardu
	Ghanche	9,400	Khaplu
Diamer	Diamer	10,936	Chilas
	Astore	8,657	Gorikot-Eidgha

2.4 DEMOGRAPHIC DETAILS

According to the census conducted in 2008 the overall population of Gilgit-Baltistan 1.8 million with population growth rate of 2.47 (PCO, 2008).

2.5 CLIMATIC CONDITIONS

Climatic conditions vary widely in the Gilgit-Baltistan, ranging from monsoon influenced moist temperate zone in the western Himalayas to the arid and semi-arid cold desert in the northern Karakorum and Hindukush. *In Gilgit-Baltistan, great range of mean monthly temperature values, low winter temperatures.* The precipitation and temperature vary with topography, altitude and aspect. Below the 3,000 meters, precipitation occurs 200 millimeters annually. Above 6,000 meters elevation snowfalls occur. The temperature in summer is 40⁰C and in winter less than -10⁰C. (Strategy of environment and sustainable development)

2.6 ECOLOGICAL ZONES

Based on ecological zonation five main types of forests exist in Gilgit-Baltistan, namely, Mountain Sub-Tropical Scrub, Mountain Dry Temperate Coniferous, Mountain Dry Temperate Broadleaved, Sub-Alpine and Northern Dry Scrub (Rao and Marwat, 2003).

2.7 LAND USE PATTERN

Gilgit-Baltistan posses' 2% agriculture land, 9.4% Forests, 22% Rangelands, 36.4% Mountains, 28% Glaciers and Others 6.2% respectively.

2.8 ENVIRONMENTAL CONCERNS

Environmental degradation including Solid waste, air pollution, water contamination and inadequate sanitation systems has major implications on health and environment. The poor are particularly vulnerable to water borne diseases such as shigellosis, hepatitis, cholera, malaria, typhoid, tuberculosis and chronic respiratory infections and water born diseases such as skin infection and eye infection. The mortality rate due to water borne diseases is 25% of overall deaths in Gilgit Baltistan. Although data for the Gilgit-Baltistan is scarce. It is clear that water and sanitation related diseases affect tens of thousands of people in the region each year. (Health department, 2010)

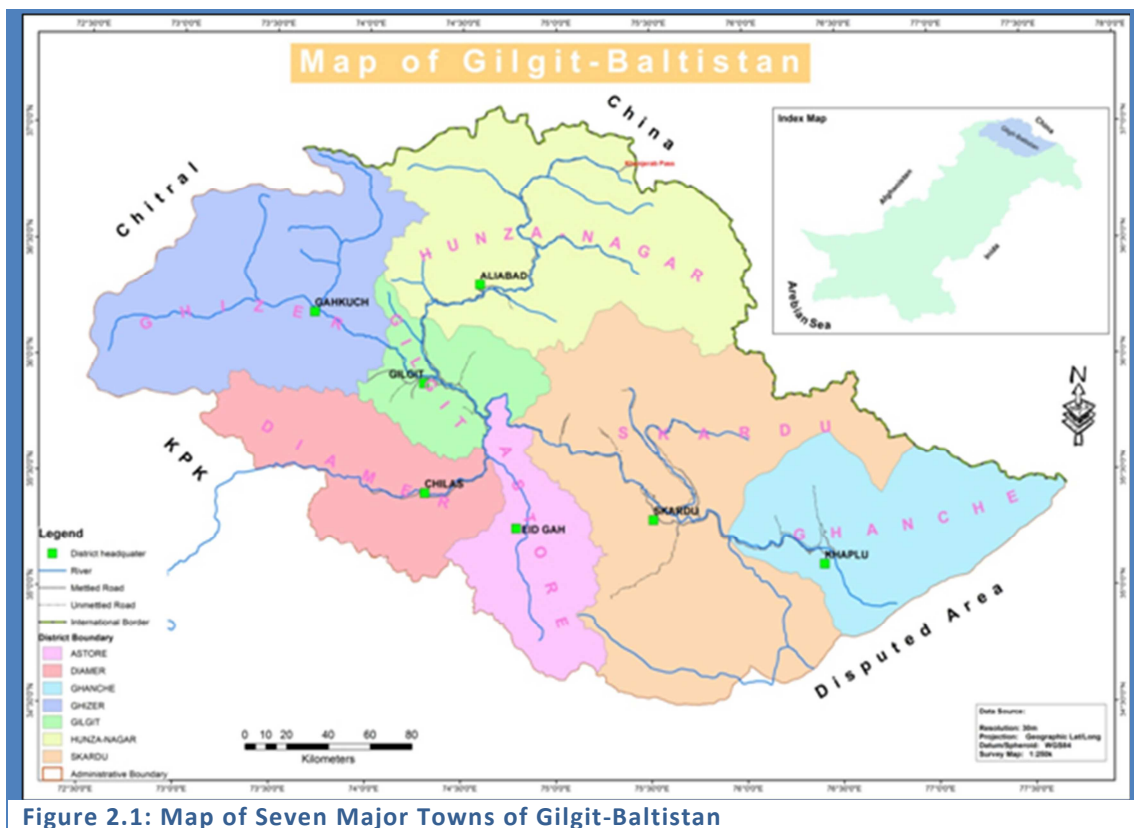

Figure 2.1: Map of Seven Major Towns of Gilgit-Baltistan

3. METHODOLOGY

Initially, a full day workshop was conducted for field teams where the members were trained in participatory assessment methodology. Later, a working group was formed from the trained with participatory assessment methodology. Groups of survey teams were formed consisting of qualified male and female staff. 3 groups of male were given assignment to conduct survey for collection of solid waste from house to house in the targeted communities. Whereas female group was assigned to conduct knowledge attitude practices (KAP) in the same communities. Domestic Solid Waste was estimated on the daily base data collection, 4 days in Gilgit and Baltistan while 3 days each in other five district of the Gilgit-Baltistan.

A random sampling technique was applied during the field survey and solid waste assessment. While sample size was followed by selection of 1000 households in overall Gilgit Baltistan. 200 households were selected in regional municipal centers i.e. Gilgit and Skardu, whereas 100 households were selected from small urban cities i.e. Gahkuch in Ghizer district, Chilas in Diamer, Aliabad in Hunza Nagar, Eidgah in Astore and Khaplu in Ghanche respectively.

3.1 TOOLS FOR ASSESSMENT

3.1.1 CHECK LIST

The assessment was carried out using checklists as basic tool and solid waste collecting polyethylene bags printed with survey and log of EPA for data collection and spring balance for measuring of organic and inorganic solid waste. For safety measures disposable gloves, facial masks, protected shoes were used during sampling of infectious wastes from hospitals. It was ensured to follow all necessary precautions by survey team members to avoid from any probable chances of infection during sampling, segregation and measuring process.

3.1.2 QUESTIONNAIRE SURVEY

Besides checklist a brief questionnaire survey was also conducted in 50 households together public responses on public perceptions and few financial topics.

3.1.3 FOCUS GROUP DISCUSSION

Each working group also conducted focus group discussions to gather information. These focus group discussions were conducted with municipal committees, women, community

based organizations, line departments, doctors and sanitary supervisors at hospitals, students and teachers in schools of all districts respectively.

3.1.4 FIELD OBSERVATION

On first day all group members visited their respective areas to give awareness about objectives of the survey and distribution of waste collection bags. The next day the teams revisited the same households to collect the waste generated with measurement tools to weight of both organic and inorganic wastes. This practice continued for four days in major cities i.e. Gilgit and Skardu whereas for 3 days in the rest of the cities in Gilgit-Baltistan.

3.1.5 SECONDARY DATA COLLECTION AND REVIEW

Existing literatures and reports related to the municipalities and solid waste were reviewed to gather the Background information of the sampled areas.

3.1.6 DOCUMENTATION INFORMATION

The first phase of report was prepared by the working group. A team leader was defined for all the team whose responsibility was to document the finding. Thus, each of the group submitted their individual findings on their assigned theme. A coordinator was also appointed to facilitate and check the overall methodology of the teams.

3.1.7 REPORT COMPILATION AND PREPARATION

The compilation task was started after receiving all the data from the field. The data was cross checked to avoid manipulation, overlaps, and contradictions in order to ensure authenticity. The filled up questionnaires were processed and analyzed.

4. FINDINGS/ RESULTS

4.1 DOMESTIC SOLID WASTE

Domestic solid waste includes garbage and rubbish and its result of domestic interventions. In developing countries, up to two thirds of this category consists of Municipal solid waste (MSW). In poor neighborhoods traditional cooking can also produce ash and where sanitation facilities are limited, the waste might also include faecal matter. Domestic waste also may contain a significant amount of hazardous waste.

Domestic solid waste in Gilgit-Baltistan is serious concern for relevant departments and agro pastoral communities in general while municipalities and conservation organizations in particular. Study reveals that 70% MSW generation from domestic activities in urban areas.

Domestic waste assessment methods were collection of 50 random samples per day from various domestic sources of three categorized classes for four consecutive days in all urban centers respectively. As defined classes A, B & C. These are economical categories, A for high income posh area, B for medium income middle class and C for low income labor and worker class.

4.1.1 GILGIT

Gilgit is the headquarters of the Gilgit-Baltistan with an elevation of 1490 meters above from sea level. Average annual rain fall is 165.4 mm, min temperature 8.3°C and max temperature 23.6°C and was recorded.

Municipal committee Gilgit is the main body and solid waste management department along with some line departments of the district Gilgit. It is evident that an efficient solid waste management system needs organizational capacity and integrated cooperation between communities, private enterprises and municipal authorities, as it is responsible for the selection and adoption of appropriate technical and local solutions for waste collection, transfer, recycling and disposal.

Here is a detailed discussion about the organizational capacity of Department of Solid Waste Management (MCG), Gilgit. Chief Officer is solid waste manager in Gilgit City and he is all over supervising solid waste management activities along with other staff of the municipal committee.

Gilgit city average family size is 8 and the total number households are around 27000. The solid waste assessment study reveals that 73 metric tons solid waste is generated per day from domestic interventions includes 76% organic while 24% inorganic waste. Domestic solid waste is major human induced hazard of the district Gilgit because of feeble capacity and

financial resources increased concerns for municipal committee and other relevant stakeholders.

4.1.2 SKARDU

Skardu city is head quarter of Baltistan division with average family size 7.5 and 20,000 households. The study reveals that 54 metric tonnes of solid waste is generated per day from domestic activities of the town where 78% organic composition materials while 22% inorganic solid waste. The population of the area has been increasing and municipal committee Skardu also faces waste management issues because of financial resource and organization profile.

4.1.3 KHAPLU

Khaplu is Head quarter of Ghanche District of Gilgit-Baltistan with family size 7.6 per household and encompass total 1667 houses in town. The survey revealed that 76% was organic waste and 24% inorganic waste. Integrated solid waste management system is a serious concern for municipal committee and line departments.

4.1.4 GAHKUCH

Gahkuch is home to 3333 households with average family size of 7.5 where domestic activities contribute 81% organic fraction and 19% inorganic solid waste. The average total solid waste generated was 9 metric tons per day from lower Gahkuch.

4.1.5 ASTORE

In Astore city, solid waste survey revealed the city has families with average 7.4 members. Keeping in consideration of the household size, a total 1727 houses are encompassed by this city. The domestic waste in the city is around 5 metric tons per day with 78% organic and 22% inorganic solid waste.

4.1.6 CHILAS

In Chilas city, solid waste survey revealed the city has large family setups with average 7.5 members. Keeping in consideration of the household size, a total 4000 houses are encompassed by this city. The domestic waste in the city is around 11 metric tons per day with 85% organic and 15% inorganic solid waste.

4.1.7 HUNZA -NAGAR

In Hunza Nagar city, solid waste survey revealed the city has big families with average 8.5 and 7.5 members respectively. Keeping in consideration of the household size, a total 3000

houses are encompassed. The domestic waste is around 5 metric tons per day with 63% organic and 38% inorganic solid waste.

Figure 4.1 presents city wise solid waste generation with population, per capita, per house and daily average.

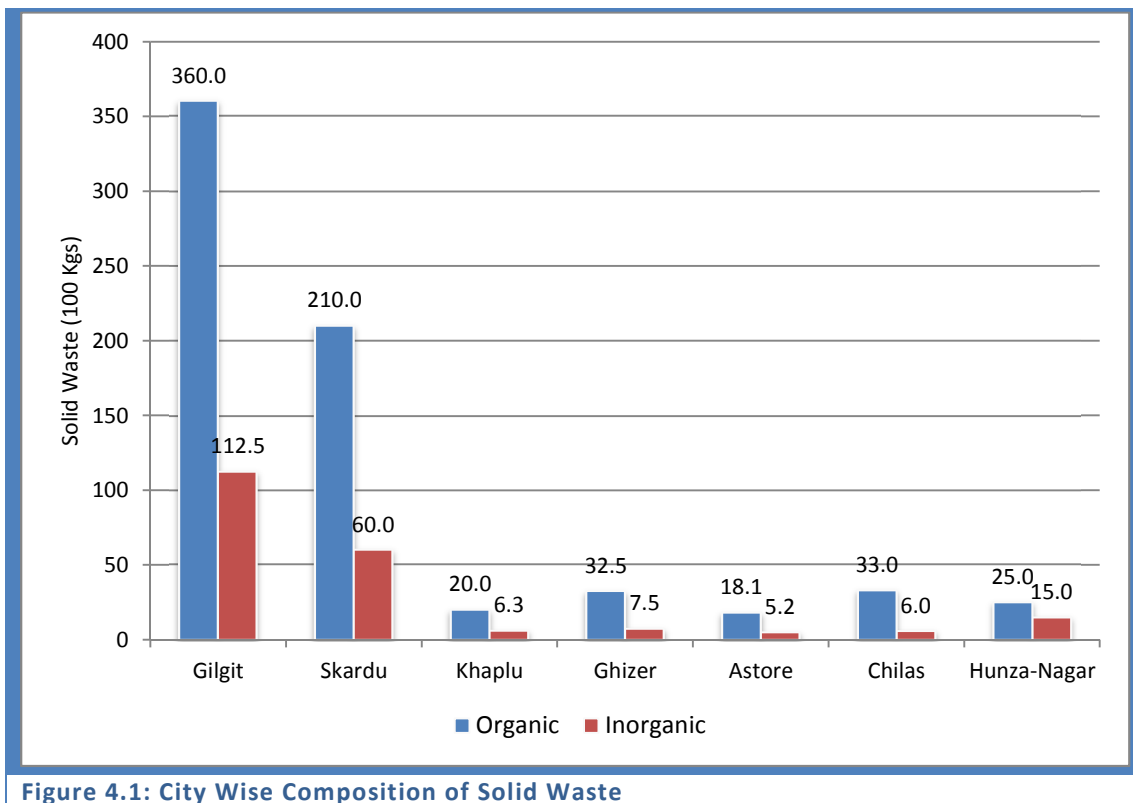

Figure 4.1: City Wise Composition of Solid Waste

4.2 COMMERCIAL WASTE

All municipal solid waste emanating from business establishments such as stores, markets, office buildings, restaurants, shopping centers, and entertainment centers or Commercial solid waste can be divided into ordinary and special solid waste. The ordinary waste contains market waste and institutional waste i.e. Kiryana shops, general stores, bakeries, spare parts, hotels and restaurants, café, shops, furniture shops, fuel pumps, banks, educational, black smiths, gold smiths, government and private offices, roads and street waste etc. the special waste contains auto workshops, medical hospital, stores and clinics, animal dung, slaughter waste, construction and demolition waste and a fraction spread in various commercial activities. Waste generation trend in all cities under scope of this study is almost same, the commercial ordinary waste contains paper, plastic bags, metal pieces, wood, rubber, food waste from restaurants, cloth pieces, bottles, glass, vegetable and fruit waste, soil and used parts of various equipment and machinery. As a total Gilgit City generates 90

metric tons, Skardu City generates 73 metric tons, Khaplu City generates 6 metric tons, Astore City generates 7 metric tons, Ghizer City generates 11 metric tons, Chilas City generates 12 metric tons and HunzaNagar generates 10 metric tons respectively. In commercial waste, contents are similar in all cities under study contain around 69% inorganic and 31% organic waste.

Figure 4.2 graphically presents commercial waste of all cities.

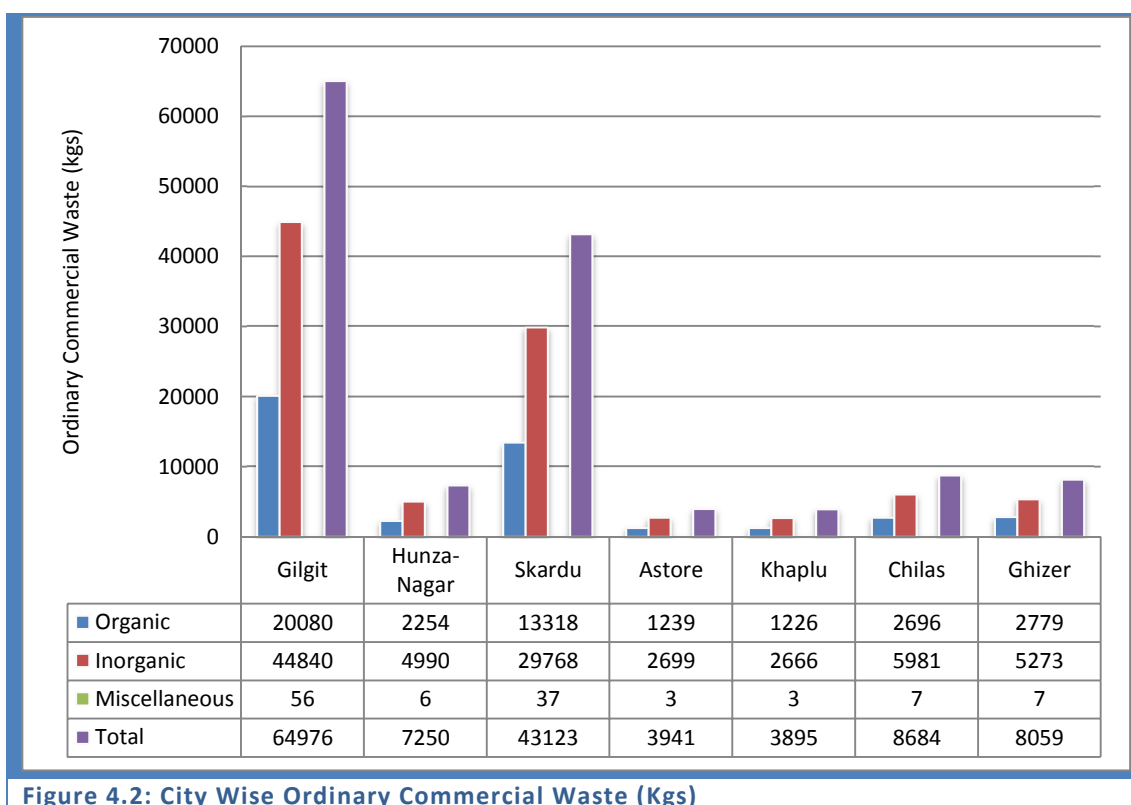

Figure 4.2: City Wise Ordinary Commercial Waste (Kgs)

4.3 SPECIAL WASTE

Special waste include Cement kiln dust, Mining waste, Oil and gas drilling mud and oil production brines ,Phosphate rock mining, beneficiation, and processing waste, Uranium waste, Utility waste (i.e., fossil fuel combustion waste) (US EPA, 1978) This waste mostly comprises of commercial and industrial waste. This waste can further be categorized as waste generated from workshops, hospitals and medical facilities, slaughter waste, animal dung, construction and demolition, dead animals and process factories of chemical, mechanical and electrical products. The major part of the special waste generated is treated as hazardous waste and needs special attention towards generation, collection and treatment. The waste generated in the cities under scope is described in **Figure 4.3** as under.

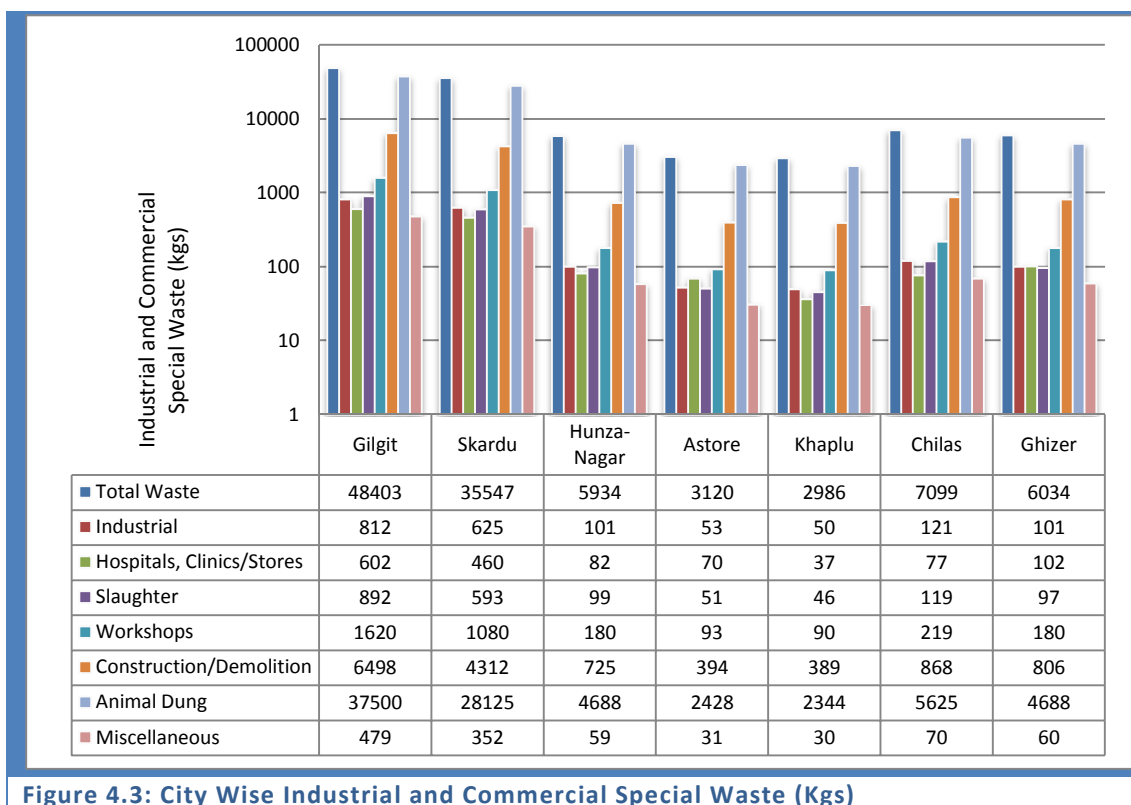

Figure 4.3: City Wise Industrial and Commercial Special Waste (Kgs)

4.4 INDUSTRIAL

A heterogeneous mixture of different materials generated during an industrial operation. It may be gaseous, liquid, sludge, and/or solid. The composition is site specific and depends upon the natural resources, raw materials and markets which provide the base for a given city's industrial activity (US EPA, 1998). Any of the cities under scope do not have major industrial development, only some wood cutting and furniture factories are situated in vicinity of all cities. Most of the waste generated is used as fuel for cooking and heating purposes at homes. However disposable waste that cannot burn due to containing soil and earth is contributes to special waste.

The industrial waste generate in all these cities is around 1.7% of the total special waste generated. Seventy percent of the industrial waste generated is used for burning purpose. This is very common trend of the area that people even do not hesitate to burn toxic and hazardous waste. The main reason behind burning this waste is to counter cold in winter, which is always in minus temperature during winter season.

In Pakistan on average a hospital bed generates 0.5 to 2 kg/day while medical waste as hazardous, 0.1 to 0.5 kg/day (Jang group 2003), In Gilgit average a hospital bed generates on average .5kg/day (Ali 2007).

Hospital waste is treated as hazardous waste because it contains mostly toxic and infectious waste. Gilgit and Skardu are the cities, which have more hospitals and medical centers, in other cities there is limited number of these facilities. The survey figures show that hospital waste generated in Gilgit, Skardu, Hunza Nagar, Astore, Khaplu, Chilas and Ghizer is 602, 460, 82, 70, 37, 77 and 102 Kgs respectively. Looking at overall figure it is 1.3% of the total special waste generated in these cities. Keeping in consideration the nature and composition of hospital waste, it requires special attention while collecting, disposing and treatment.

Looking at the city wise survey data, there are two main hospitals in Gilgit one is City Hospital Kashrote and other District Head Quarter Hospital. DHQ deals with five districts of Gilgit whereas City hospital covers the main city and surroundings

During survey it was revealed that in all cities hospital waste contains inorganic toxic and infectious waste as major part of solid waste, while organic waste comprise a small part of waste generated from food consumption. A substantial part of this waste like syringes, surgical wastes, blood bags, body parts etc are very infectious. For management of these wastes professional and trained sanitary staff is scarce, and the existing staff lacks in proper handling of wastes.

A general practice observed in all hospitals is dustbins placed with every bed in the wards, waste is collected through sweeping in the corridors and compound and further it finds its way in municipal waste collection system. No any container or dumping sites placed by MC, while the hospital administration dump the waste and fire in the backyard of hospitals.

Only one functional incinerator found in DHQ Gilgit installed in year 2000 and while others are non functional and need major repair maintenance as well as training for operators and development of operational mechanism. According to the hospital authorities infectious and body parts are buried in the ground below 6 ft but practically we observed that nothing done for this purpose and body parts, blood bags, infectious waste and other waste are dumped near the container fixed by municipality, from there the municipality disposed off in the open field near municipal dump sites.

4.5 SLAUGHTER WASTE

Thousands of animals are slaughtered every year in Pakistan, but unfortunately there is neither proper mechanism nor waste water management system to handle the effluent discharge of the slaughtering process (Ali et al, 2010) Slaughter waste includes meat, bones, feathers, leather, blood and dung waste (WWF, 2007).

4.5.1 GILGIT

In Gilgit, slaughtering is done in the city and slaughter house. A public slaughter house owned by MC Gilgit is being used for slaughtering of animals, which lacks in proper system

for segregation, collection and disposal of slaughter waste. It is situated at the bank of Gilgit River in Basin Khari about 4 KM from Gilgit City. According to them about 25-30 small and 12-15 big animals daily slay at slaughter house. In addition to it chicken and other meat slaughtering is done in the city and the waste generated exceeds the waste generated from slaughter house. On daily basis an average 2 ton slaughter waste is generated in the city.

4.5.2 SKARDU

In Skardu, there is no MC slaughter house exists; a private plot covered by boundary wall rented on Rs.1200 per month is being used since last twenty years. Due to lacking proper MC slaughtering place there is no proper system for segregation, collection and disposal of slaughter waste. According to people opinion and MC about 20 small and 15 big animals daily slay here. In addition to it chicken and other meat slaughtering is done in the city and the waste generated exceeds the waste generated from slaughter house. The MC authority has strictly given instruction to the poultry shops for construction with connection to tap water available to flush out and drain the bloods and waste. And some were found with proper apron and washing places for while cutting of chicken. On daily basis an average 1.4 ton slaughter waste is generated in the city.

4.5.3 HUNZA-NAGAR

In Hunza Nagar, there is no proper slaughter house of municipal committee and open free space is used as slaughtering place which lacks in proper system for segregation, collection and disposal of slaughter waste. According to people opinion and MC average 5 small and 2 big animals daily slay here. In addition to it chicken and other meat slaughtering is done in the city and the waste generated exceeds the waste generated from slaughter house. On daily basis an average 100 Kg's slaughter waste is generated in the city.

4.5.4 ASTORE

In Astore city, there is no any proper slaughter place of municipal committee in the city whereas private open spaces near water stream or water channels is used as slaughtering animals, which lacks in proper system for segregation, collection and disposal of slaughter waste. According to people opinion and MC average 2 small and 1 big animals daily slay here. In addition to it chicken and other meat slaughtering is done in the city and the waste generated exceeds the waste generated from slaughter house. On daily basis an average 50 kgs slaughter waste is generated in the city.

4.5.5 KHAPLU

In Khaplu Town, there is no any proper slaughter place of municipal committee in the city whereas private open spaces near water stream or water channels is used as slaughtering animals, which lacks in proper system for segregation, collection and disposal of slaughter

waste. According to people opinion and MC average 1 small and 1 big animals daily slay here. In addition to it chicken and other meat slaughtering is done in the city and the waste generated exceeds the waste generated from slaughter house. On daily basis an average 46 kgs slaughter waste is generated in the city.

4.5.6 CHILAS

In Chilas City, there is no any proper slaughter place of municipal committee in the city whereas private open spaces near water stream or water channels is used as slaughtering animals. Due to lack of proper facility there is no proper system for segregation, collection and disposal of slaughter waste. According to people opinion and MC average 3 small and 2 big animals daily slay here. In addition to it chicken and other meat slaughtering is done in the city and the waste generated exceeds the waste generated from slaughter house. On daily basis an average 100 kgs slaughter waste is generated in the city.

4.5.7 GHIZER

In Ghizer City, there is no any proper slaughter place of municipal committee in the city whereas private open spaces near water stream or water channels is used as slaughtering animals. Due to lack of proper facility there is no proper system for segregation, collection and disposal of slaughter waste. According to people opinion and MC average 5 small and 3 big animals daily slay here. In addition to it chicken and other meat slaughtering is done in the city and the waste generated exceeds the waste generated from slaughter house. On daily basis an average 150 kgs slaughter waste is generated in the city.

In all cities, slaughter houses lack in the proper facilities. A part of waste is segregated through collection channel around the slaying area, separate storage tanks for animal excreta and leather wastes. Waste generation and collection do not have special attention. The waste is used as organic manure, meat is eaten by cats, dogs and other animals and remaining disposed in backyard or in vicinity of slaughter house at the sake of municipal collection and disposal system.

4.6 AUTO MOBILE WORKSHOPS

In Gilgit-Baltistan auto mobile workshops waste were recorded as Oil filters, Oily rags, Coolants, Waste oil, Water, Brake fluid and Drums. In all cities workshops for the automobiles have similar waste generation practices. The waste generated from workshops is mostly resold and the remaining picked by scavengers, a very small portion find its way in municipal waste collection system and disposed at dump sites.

Average waste generated from workshops is 1620, 1080, 180, 93, 90, 216, 180 kg for cities of Gilgit, Skardu, Hunza Nagar, Astore, Khaplu, Chilas and Ghizer respectively, it contributes 3.2% of the total special waste from all sources.

4.7 ANIMAL DUNG

Major types of the animals in Gilgit- Baltistan are Cows, goats, sheep's, buffalos, donkeys, yak, and horse. Mostly this animal dung used as manure in all parts of the Gilgit-Baltistan but in town areas particularly Gilgit and Skardu this waste have impacts on aesthetic and water quality. Animal dung is major part of the special waste generated in the cities under our study. According to survey data, an average more than 40% of the total special waste generated is animal dung.

In Gilgit, 40% of the city population is attached with placing and feeding live stock domestic animals in their houses. Normally animals grazed are cow and goat; in Astore, donkey is also used for transportation of material etc. Similar types of animals are observed in the other cities of this region. In Skardu and other five cities average 45% to 60% of the population have livestock animals in their houses.

The average dung waste generated is 37, 28, 4.6, 2.4, 2.3, 5.6 and 4.6 tons in Gilgit, Skardu, Hunza Nagar, Astore, Khaplu, Chilas and Ghizer cities respectively. The average dung waste generated in all cities is around 78 % of the total special waste generated.

4.8 CONSTRUCTION AND DEMOLITION WASTE

Gilgit-Baltistan is an under developed area and construction of new infrastructure and market extension in town areas generate considerable amount of demolition waste which are reused in reconstruction activities but some waste remain issues of the municipalities and waste management authority to transport and disposed off

Construction and demolition is a continuous activity as a part of new development and rehabilitation of the old structures in any planned city. Construction and Demolition waste mostly contains stone, concrete blocks, iron pieces, wood, tiles, marble pieces and soil material. Generally the major part of this waste is used in backfilling and also reused in construction works; only 30% find its way to municipal collection system and finally dumped at the MC disposal site.

This waste generated, when considered in volume is small, whereas in case, compared with the waste generated from other activities in mass it contributes a lot. Average waste generated from construction and demolition activities is 6.4, 4.3, 0.7, 0.3, 0.3, 0.8, 0.8 tons

for cities of Gilgit, Skardu, Hunza Nagar, Astore, Khaplu, Chilas and Ghizer respectively, it contributes 13% of the total special waste from all sources.

4.9 SEASONAL TRENDS OF WASTE GENERATION AND UTILIZATION

Burning of Solid waste is common practice in Gilgit-Baltistan like other parts of the Pakistan, plastic bags, cotton, wood pieces, Newspapers, papers, cards, cardboard, tissue papers, packaging material (wrappers) and sweets wrappers are common waste which are common items which are burn for cooking and heating purpose in town areas particularly in winter season. In all cities, burning of solid waste is a quite normal trend in winter; this is done to counter the heavy cold, which normally is in minus temperature. During winter an average 35 to 50 % of the total waste generated is utilized in burning. Due to this practice heavy layers of smoke are generally seen in the sky, causing major environmental damage and massive contribution to greenhouse gases. Generally the major portion of the solid waste generated is burned in the cities under scope of this study i.e 30, 45, 40, 35, 35, 40 and 15% in Gilgit, Skardu, Ghizer, Hunza -Nagar, Astore, Khaplu and Chilas respectively.

4.10 COLLECTION AND DISPOSAL SYSTEM

The solid waste has been to be picked up from the ground manually with the help of handcarts; baskets and in polythene bags in all towns of the Gilgit-Baltistan. Irregular and uncontrolled sweeping, particularly in rush hours, creates problems for the general public. Average amount of sweeping collected in commercial areas is 10-12 kg/sweeper/day (Ali, 2007). In non-commercial areas, however, the average collection is 5kg/sweeper/day (admin officer MCG, 2004). With the equipment and machinery available with the MCG, maximum collection capacity of 15 tons/day can be achieved in Gilgit. The balance uncollected waste is 10 tons/day. This shows that there is a shortfall in lifting capacity of solid waste from jurisdiction of MCG. Only about 50 -55% of solid waste is collected and transported to dumping sites. The remaining waste is either burnt or remains on streets or in residential areas most of which is thrown in drains, Hence the system creating another environmental health problem in the area. This increases the susceptibility to environmental pollution and causes many diseases associated with solid wastes in the town area.



4.10.1 PRIMARY COLLECTION

In Gilgit, primary collection of the waste is outsourced, carried through contractor for sweeping of main roads and main markets, while residential streets are swept by the MC sanitary staff. There are around 1000 waste bins installed at various locations of the city for this purpose. Contractors services also covers sweeping of main and link roads of the city. Due to lack of human and financial resources, MC can't afford door to door collection of waste. During survey it was revealed that the people are unwilling to pay even a small amount against their waste collection and disposal system of their area. Some markets like NLI Market, Col Hassan Market; have their own paid sweeping arrangement, disposing their waste at nearby MC containers.

Skardu and other cities also have own municipal arrangements for primary collection, while the collection practices are almost similar in all cities. In all these cities, the primary collection is done on daily basis with 50 - 60% efficiency overall. In addition to bins; there are several heaps in each area of the city. During the primary collection more than 30% of the waste goes unattended, scattered and un-collected and 5-10% finds its way to open sewers and drains.

Primary collection of construction and demolishing waste depends on need bases.

4.10.2 SECONDARY COLLECTION

In all seven cities, at present, the solid waste collection system is mostly based on manual labor arrangements. However, the final practices need particular attention as the trend is for open dumping without considering any hygienic factors. There are mostly open places designated for open dumping. This practice is adopted through tens of years.

The residents throw their solid waste on sides of the streets making small heaps. This trend is quite common throughout all the cities. These small street side heaps are cleared by sweepers using handcarts and taken to the filth depots or metallic containers or the filth depots.

Due to indiscriminate throwing of solid waste, sweepers often have a tough task, thus many streets are rarely cleaned. The tools provided to the sweepers are of poor design and quality.

Proper transfer stations do not exist in all the town areas. However, 5 places can be considered transfer stations (MCG sources) the waste is transferred from handcarts to these locations. They create unsafe environment work in the town area, as most of them are located along roads. The current practice of solid waste collection and transfer at the filth dumpsters is unsanitary and dangerous method of resource recovery.

In Gilgit, for secondary collection, MC fixed 50 metal containers with two wheels. These were supposed to pull by the tractors when these filled with waste. This was an

improvement in the conventional practice of waste collection and transportation. There were constructed 40 masonry points in year 2006, most of these are demolished by thieves to take away blocks and iron, and currently only 10 of these are in place. In addition to it, there are about 100 open heaps spaces as secondary collection points.

In Skardu and other cities insufficient number of containers are fixed at need based locations. Major part of waste collects in form of small and large heaps. Municipal committees of these cities do not have engineering criteria to fix the points of containers placements; therefore the existing system relies on need based containers installation mechanism only.

The current storage, collection, transfer and solid waste disposal facilities in Gilgit are shown in **Table 4.1**:

Table 4.1: Solid Waste Management System, All Cities at a Glance

A-Major Cities: Gilgit and Skardu						
Storage at the Premises	Collection from Premises	Storage on Street sides	Collection from Streets	Transfer Station	Transfer Vehicle	Disposal
Make shift container	Manually	Street side heaps	Wheel Barrows/ Hand carts	6 m3 containers/ filth depots	Tractor trolleys/ open body trucks	Open dumping sites
	Hand Carts	→		6 m3 containers/ filth depots	Tractor trolleys/ open body trucks	Open dumping sites
Street sweeping/ water channel and open sewer cleaning		Street side heaps	Hand carts and wheel barrows	6 m3 containers/ filth depots	Tractor trolleys/ open body trucks	Open dumping sites
B-Secondary Cities: Ghizer, Chilas, Hunza Nagar, Astore and Khaplu						
Storage at the Premises	Collection from Premises	Storage on Street sides	Collection from Streets	Transfer Station	Transfer Vehicle	Disposal
Make shift container	Manually	Street side heaps	Wheel Barrows/ Hand carts	3 m3 containers/ filth depots	Tractor trolleys/ open body trucks	Open Dumping at MC designated sites

	Hand Carts	→		3 m3 containers/ filth depots	Tractor trolleys/ open body trucks	Open Dumping at MC designated sites
Street sweeping/ water channel and open sewer cleaning		Street side heaps	Hand carts and wheel barrows	3 m3 containers/ filth depots	Tractor trolleys/ open body trucks	Open Dumping at MC designated sites

4.11 TRANSFER AND TRANSPORT

The vehicles and equipment available with solid waste institutions in all town areas are limited, which is a serious concern for solid waste management department of Gilgit-Baltistan for appropriate waste management.

4.11.1 GILGIT

In Gilgit, approximately 163 metric tons of domestic and commercial waste is being generated in the city. Around 35-40% of the total generated waste is handled by MC. This solid waste is transferred manually into tractor trolleys and dumper trucks which is ultimately disposed off in the form of open dumping at Chilmas Das a municipal committee designated site.

4.11.2 SKARDU

In Skardu, approximately 127 metric tons of domestic and commercial waste is being generated in the city. Around 40-45% of the total generated waste is handled by MC. This solid waste is transferred manually tractor trolleys and dumper trucks which is ultimately disposed off in the form of landfill at Sondus a municipal committee designated site.

4.11.3 CHILAS

In Chilas, approximately 23 metric tons of domestic and commercial waste is being generated in the city. Around 45-50% of the total generated waste is handled by MC. This solid waste is transferred manually into tractor trolleys which is ultimately disposed off in the form of open dumping at a 4 canal committee designated site which is located at a distance of 4km from city

4.11.4 GHIZER

In Ghizer, approximately 20 metric tons of domestic and commercial waste is being generated in the city. Around 45-50% of the total generated waste is handled by MC. This solid waste is transferred manually into tractor trolleys which ultimately is disposed off in the form of land filling at a 5-6 canal Municipal Committee designated site

4.11.5 TRANSFER AND TRANSPORT IN ASTORE

In Astore, approximately 12 metric tons of domestic and commercial waste is being generated in the city. Around 45-50% of the total generated waste is handled by MC. This solid waste is transferred manually into tractor trolleys which is ultimately disposed off at 3km away from the city in form of open dumping.

4.11.6 HUNZA-NAGAR

In Hunza Nagar, approximately 15 metric tons of domestic and commercial waste is being generated in the city. Around 45-50% of the total generated waste is handled by MC. This solid waste is transferred manually into tractor trolleys which is ultimately disposed off in the form of open dumping at a 4 canal municipal committee designated site

4.11.7 KHAPLU

In Khaplu, approximately 11 metric tons of domestic and commercial waste is being generated in the city. Around 30-35% of the total generated waste is handled by MC. This solid waste is transferred manually into tractor trolleys and dumper trucks which is ultimately disposed off in the form of open dumping private site.

Table 4.2: District-wise Number of Vehicles, with Waste Lifting Capacity and Condition

City	Vehicle Type	# of Vehicles	Lifting Capacity	Conditions
Gilgit	Wheel Barrows	25	10-15 KG	Functional
	Handcarts	5	25-30 KG	Functional
	Tractor MF240	5	800-1000 KG	Functional
	Tractor MF 375	1	1000-1200 KG	Functional
	Dumper Truck	1	1500-1800 KG	Functional
Skardu	Tractor MF 240	2	800-1000 KG	Functional
	Tractor MF 385	2	1000-1200 KG	Functional
Chilas	Tractor	2	800-1000 KG	Functional
Hunza Nagar	Tractor	1	800-1000 KG	Functional
Ghizer	Hand Cart	10	20-30kg	Functional
	Tractor MF 375	2	250-300	1 Functional

City	Vehicle Type	# of Vehicles	Lifting Capacity	Conditions
	Tractor MF 240	1	800-1000 KG	Non Functional
Astore	Tractor	1	800-1000 KG	Non Functional
Khaplu	Tractor	1	800-1000 KG	Non Functional

4.12 FINAL DISPOSAL

Disposal of solid waste is carried out in the form of open dumping in depressions in out skirts of the city. The plastic bags in the windy season spread flying in the air and cause inconvenience to the moving traffic. 45 %of waste is being openly disposed off at the only official designated disposal site named Chilmes Das, situated near KIU at a distance of 13km from the main city.



In Skardu its disposed off at MC disposal site at Sondus with around 1500 Kanal land. All dump sites with respect to city, distance and area are presented in **Table 4.3**.

Table 4.3: City Wise Dump Sites

Sr. No	City	Dump Site	Area	Distance from City
1	Gilgit	Chilmas Das	100 Kanal	13 km
2	Skardu	Sondus	100 Kanal	8 km
3	Chilas	-	4 Kanal	4 km
4	Hunza Nagar	-	4 Kanal	6 km
5	Astore	-	4 Kanal	3 km
6	Ghizer	-	5-6 Kanal	3 km
7	Khaplu	-	6 Kanal	3 km

4.13 SOLID WASTE SEGREGATION

4.13.1 RECOVERY OF REUSABLE AND RECYCLABLE MATERIAL

In all cities, reusable and recyclable material is not properly and sufficiently being recovered. In Gilgit, there are about 20 kabaria shops in the city, paper, plastic pieces etc. are being sold to them, in city there is insufficient number of professional scavengers as well as there is no

any proper system to monitor these scavengers. For all cities domestic and commercial solid waste reusables recovery is graphically presented in **Figure 4.4** and **4.5**.

Table 4.4: Recyclable Items in Municipal Waste of Gilgit-Baltistan

Glass	Window glass, crockery glass, mirror, electric bulbs and tube rods, fancy decorations pieces, medicine bottles, beverage bottles, cosmetics residues
Plastics	Crockery, pens and ball points, electric wares, covers of electronic goods, packaging material, plastic syringes, plastic foot wears, straws, bottle lids, food cans, computer waste, cosmetics residues, shopping bags
Papers	Newspapers, papers, cards, cardboard, tissue papers, packaging material (wrappers), sweets wrappers
Bones	Animal bones
Metals	Iron, steel, Aluminum, syringe needles, wires, drink cans, crockery, old battery cells
Wood	Garden waste, wood trimmings, furniture works residues and leaves

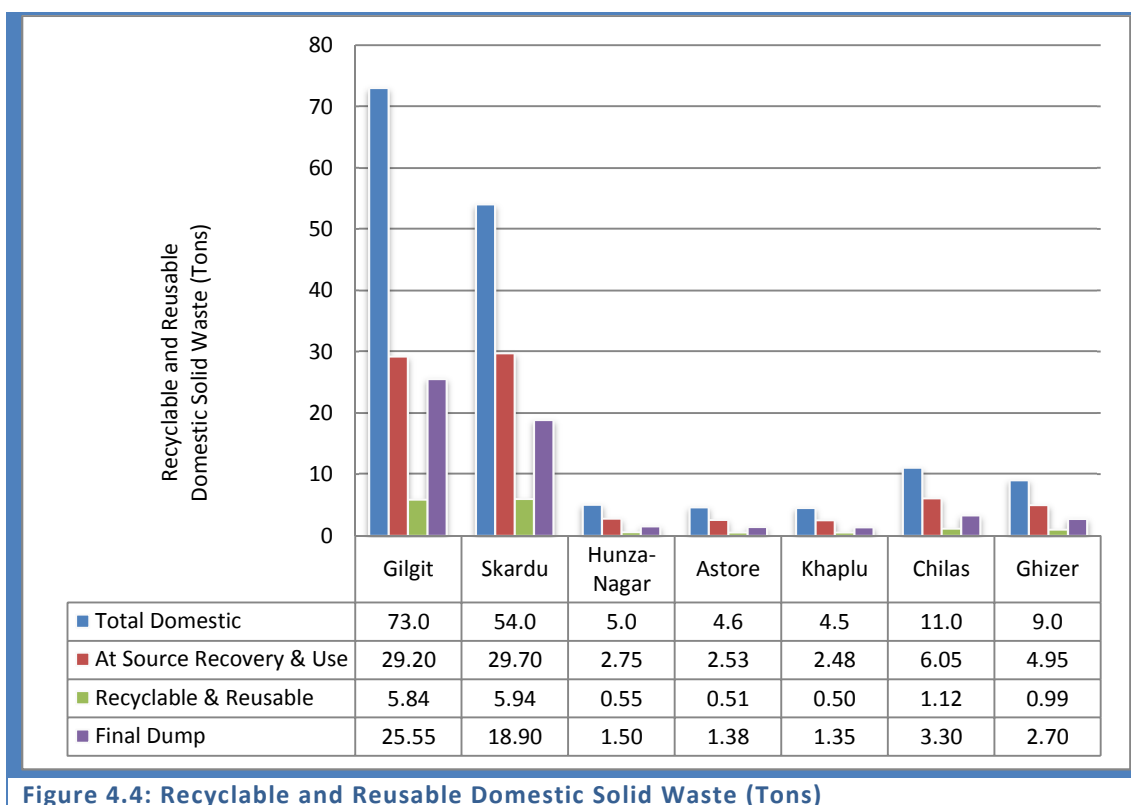

Figure 4.4: Recyclable and Reusable Domestic Solid Waste (Tons)

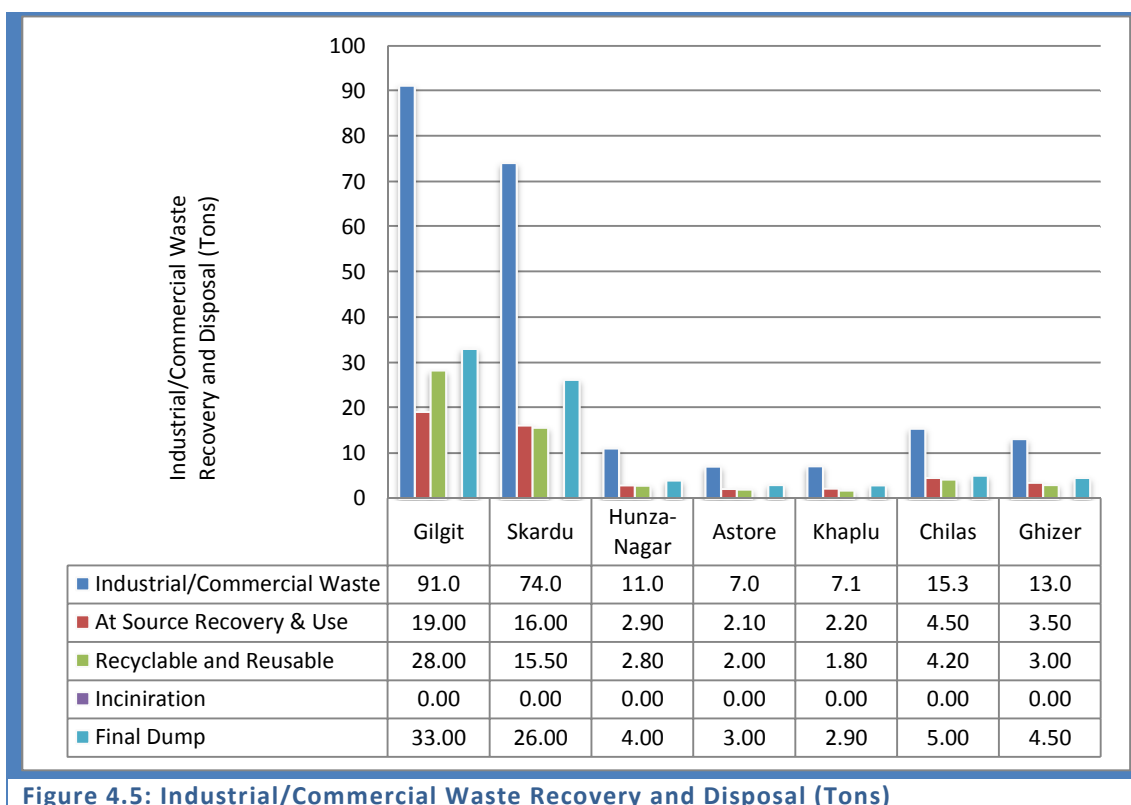

Figure 4.5: Industrial/Commercial Waste Recovery and Disposal (Tons)

4.14 ADMINISTRATIVE AND INSTITUTIONAL MECHANISM

4.14.1 ADMINISTRATIVE MECHANISM

Principally the Chairman (Municipal Committee) is the incharge of all municipal services of the city. As for solid waste the chief officer is responsible for entire city. Whereas during the interim period of local govt. elections the Assistant Commissioner of the city deliver the duties as administrator of the Municipal Committee until next chairman is being elected. Number of staff with respect to city and designation is given in **Table2.4**. The municipal committee organogram for all cities is as under:

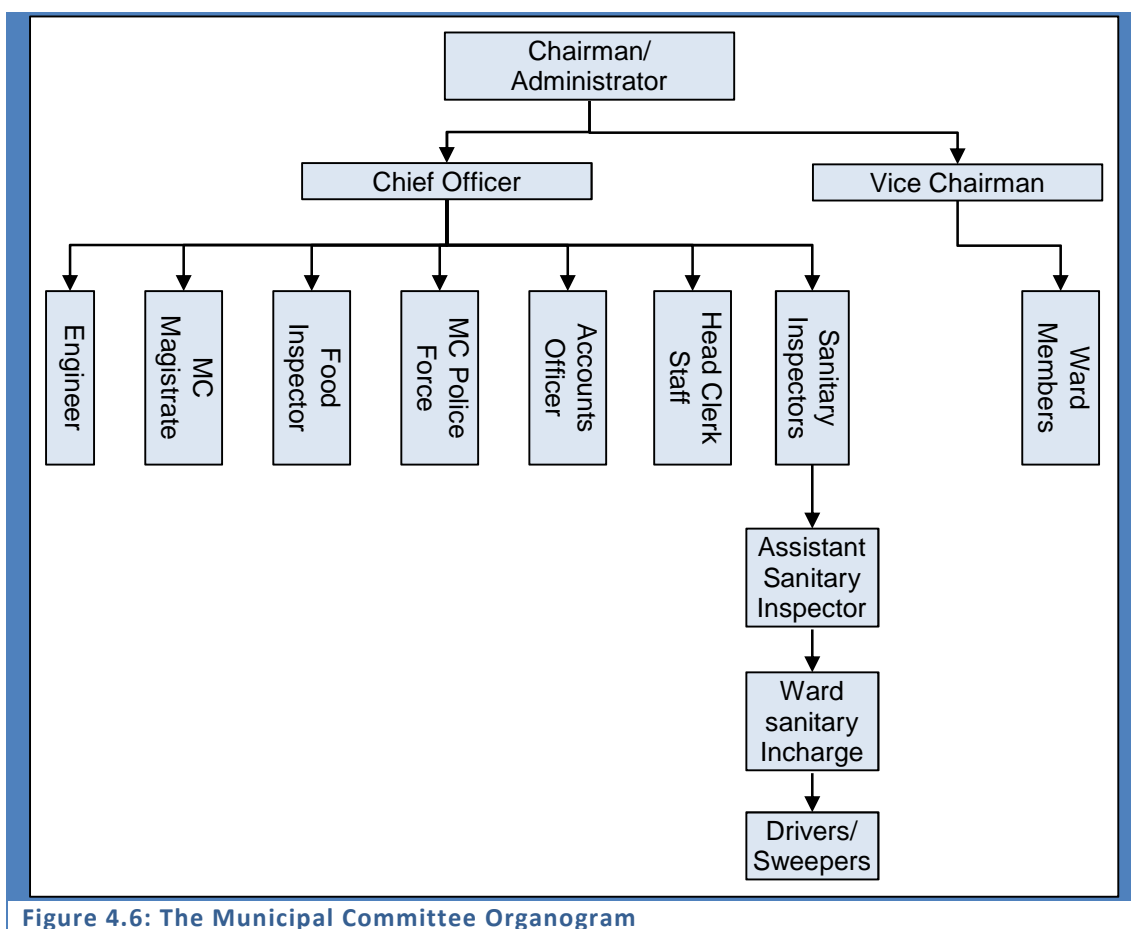

Figure 4.6: The Municipal Committee Organogram

Table 4.5: Available Staff for Solid Waste Management in Gilgit-Baltistan Urban Centers

City	Chief Sanitary Inspector	Sanitary Inspectors	Asstt. Sanitary Inspectors	Jamadar/ Beat Incharge	Sanitary Worker	Road Qully	Drivers	Total
Gilgit	1	1	2	8	50	0	14	75
Skardu	0	1	3	1	55	10	5	75
Chilas	0	1	1	1	25	0	2	30
Astore	0	1	1	1	15	0	2	20
Ghizer	0	1	1	1	15	0	2	20
Hunza Nagar	0	1	1	1	15	0	1	19
Khaplu	0	1	1	1	15	0	1	19

4.15 FINANCIAL MECHANISM

Street sweeping and solid waste collection are the two major heads for spending money on solid waste management. This includes the salaries of the staff, fuel for vehicles, repair and maintenance and purchase of new equipment and vehicles. According to the Municipal committee Gilgit, the total amounts of expenses incurred on solid waste management in the city are PKR 29,640,000/- For all other cities, budget is mentioned in **Table 4.6**.

Table 4.6: Budget Details for Solid Waste in 2009-10 (Million Rupees)

Sr. No	City	Salaries	POL & Maintenance	Admin	Sanitary items	Total
1	Gilgit	20.6	2.8	2.00	0.20	25.0
2	Skardu	20.0	2.0	2.20	0.10	24.3
3	Chilas	6.0	1.0	3.45	0.15	10.6
4	Astore	3.7	2.0	1.00	0.10	5.8
5	Ghizer	4.7	1.0	-	0.10	5.8
6	Hunza Nagar	4.0	1.0	1.00	0.10	6.1
7	Khaplu	5.0	2.0	1.00	0.10	8.1

4.16 CAPACITY EVALUATION

4.16.1 EQUIPMENT AND MACHINERY CAPACITY

In all cities equipment and machinery is insufficient and old, do not cater the requirement of the solid waste collection system. All machinery used is under efficiency around 60 %. The detail efficiency analysis is presented in **Table 4.7**:

Table 4.7: Equipment and Machinery Capacity

City	Vehicle Type	# of Vehicles	Lifting Capacity of each	Density Tons/m3	Lifting Efficiency
Gilgit	Wheel Barrows	25	10-15 KG	0.4	70
	Handcarts	5	25-30 KG	0.4	70
	Tractor MF240	5	800-1000 KG	0.4	60
	Tractor MF 375	1	1000-1200 KG	0.4	60
	Dumper Truck	1	1500-1800 KG	0.4	60

City	Vehicle Type	# of Vehicles	Lifting Capacity of each	Density Tons/m ³	Lifting Efficiency
Skardu	Tractor MF 240	2	800-1000 KG	0.4	60
	Tractor MF 385	2	1000-1200 KG	0.4	60
Chilas	Tractor	2	800-1000 KG	0.4	60
Hunza Nagar	Tractor	1	800-1000 KG	0.4	60
Ghizer	Hand Cart	10	20-30kg	0.4	70
	Tractor MF 375	2	250-300	0.4	60
	Tractor MF 240	1	800-1000 KG	0.4	60
Astore	Tractor	1	800-1000 KG	0.4	60
Khaplu	Tractor	1	800-1000 KG	0.4	60

4.17 EFFICIENCY OF WASTE COLLECTION AND DUMPING

In all cities, the data analysis shows that approximately 49 - 51% of the total commercial and domestic waste is either reused at domestic level or picked by the scavengers. This all waste is of valuable nature containing, paper, wood, metals, plastic and reusable organics. Around 14 - 21 % of the total waste is left unattended either scattered or goes to sewer and drains. Only 30 - 35 % of the waste keeps the attention of municipal waste collection system. Of this waste only 58 - 72 % is collected and openly dumped at the risk to environment.

The tables below show mass efficiency and percentage efficiency evaluation of solid waste for all cities.

Table 4.8: Dumping Efficiency in Kilograms

City	Total Waste generated	Recycled/ reused	Left Unattended	final dumping	Collection and Dumping efficiency in %
Gilgit	163	80.04	25.91	57.05	69
Skardu	127	64.84	17.71	44.45	72
Hunza Nagar	15	7.3	3.2	4.5	58
Astore	11.2	5.676	2.164	3.36	61
Khaplu	11	5.57	2.13	3.3	61
Chilas	25.6	13.1	4.82	7.68	61
Ghizer	21.5	10.94	4.11	6.45	61

Table 4.9: Dumping Efficiency in Percentage

city	Total Waste generated in Kgs	Recycled/reused %	Left Unattended %	left for Municipal Collection %	Collection and Dumping efficiency %
Gilgit	163	49	16	35	69
Skardu	127	51	14	35	72
Hunza Nagar	15	49	21	30	58
Astore	11	51	19	30	61
Khaplu	11	51	19	30	61
Chilas	26	51	19	30	61
Ghizer	22	51	19	30	61

4.18 SHORT COMING

The short comings in the existing system along with the mitigation measures to curtail those limitations are narrated in the following paragraphs;

4.18.1 COLLECTION EFFICIENCY

Collection efficiency is only 58 - 72 % of the 30 - 35 % waste accounted in the collection system. To make the city clean it needs to be raised up-to 90%, which is a practical figure under the local situation. Also the domestic and commercial waste reused at home level needs to be reevaluated to make it reused in environment friendly manners.

4.18.2 STREET SIDE HEAPS/FILTH DEPOTS

Shortcomings/Problems:

- Rodents become quite active in these street side open dumps. These are also breeding places for flies and source of other disease causing organisms.
- Open heaps are the constant sources of obnoxious odors and unhygienic conditions.
- The wastes in open heaps scatter all over the surrounding areas as a consequence of scavenging activity and wind action and clog the open drains and sewers.

Proposed Measures:

- The filth depots and street-side heaps need to be replaced by metallic containers.

4.18.3 HAND CARTS

Shortcomings

- It is very small and is cumbersome for the user. It is also very low in structure so the person using the hand cart has to bend down a great deal to push it which is quite painstaking.
- The wastes carried in the hand cart can only be tipped on the ground. There is no arrangement for direct discharge into the containers.
- Previously, the hand carts only had the bushes, however, the bushes are now replaced with bearings but these bearings need periodic tuning which unfortunately does not happen.

Proposed Improvements

- The design of the hand cart needs to be modified to increase its capacity to manageable size of about 200 liters. A modified form of the hand cart is shown in **Figure 4.7**.
- The arrangements should be made to directly unload the wastes into the container by making the arrangement in the back of the cart (opening).

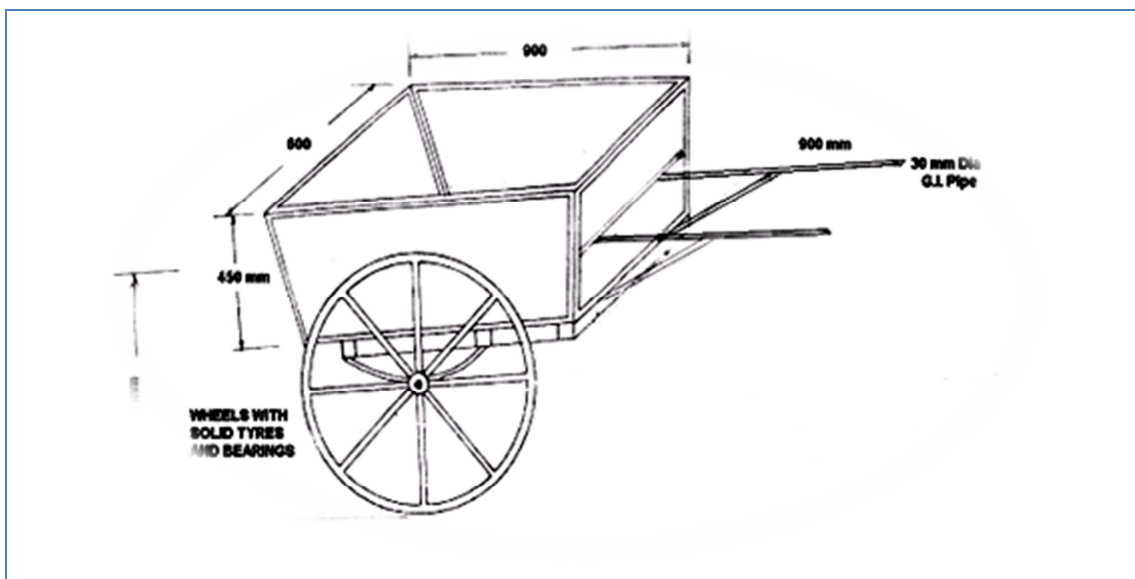

Figure 4.7: Modified Hand Cart

4.18.4 TRACTOR TROLLEYS AND OPEN BODY TRUCKS

Shortcomings

- These tractor trolleys are performing the collection job perfectly as per their design, but being small in size these are not suitable for direct haul to the disposal site.

Proposed Improvements

- They should be used for their life, and phased out by replacing them with mechanically operated hoist trucks.

4.18.5 OPEN DUMPING

Shortcomings

- Disposal of solid wastes is in the form of haphazard open dumps, and is a constant source of environmental pollution.

Proposed Improvements

- The practice needs to be replaced by proper sanitary land filling and composting.

5. THE NEED TO ADAPT WESTERN TECHNOLOGIES AND MANAGEMENT SYSTEMS/ RECOMMENDATIONS

Technologies and management systems, which are used in developed countries, need to be adapted to the local situation.

5.1 WASTE MANAGEMENT TECHNIQUES

Managing domestic, industrial and commercial waste has traditionally consisted of collection, followed by disposal. Depending upon the type of waste and the area, a level of processing may follow collection. This processing may be to reduce the hazard of the waste, recover material for recycling, produce energy from the waste, or reduce it in volume for more efficient disposal. Collection methods vary widely between different countries and regions, and it would be impossible to describe them all.

5.2 LANDFILL

Characteristics of a modern, well-run landfill should include methods to contain leachate, such as clay or plastic liners. Disposed waste should be compacted and covered to prevent vermin and wind-blown litter. Many landfills also have a landfill gas extraction system installed after they are closed to extract the gas generated by the decomposing waste materials. This gas is often burnt to generate power. Generally, even flaring the gas off is a better environmental outcome than allowing it to escape to the atmosphere, as this consumes the methane (a far more potent greenhouse gas than carbon dioxide).

5.3 INCINERATION

Incineration is the process of destroying waste material by burning it. Incineration is carried out both on a small scale by individuals and on a large scale by industry. It is recognized as a practical method of disposing of hazardous waste materials (such as biological medical waste). Though still widely used in many areas (especially developing countries), incineration as a waste management tool is becoming controversial for several reasons. First, it may be a poor use of many waste materials because it destroys not only the raw material, but also all of the energy, water, and other natural resources used to produce it. Some energy can be

reclaimed as electricity by using the combustion to create steam to drive an electrical generator, but even the best incinerator can only recover a fraction of the caloric value of fuel materials. Second, incineration creates toxic gas and ash, which can harm local populations and pollute groundwater. Modern, well-run incinerators take elaborate measures to reduce the amount of toxic products released in exhaust gas. But concern has increased in recent years about the levels of dioxins that are released when burning mixed waste. Until recently, safe disposal of incinerator waste was a major problem. In the mid-1990s, experiments in France and Germany used electric plasma torches to melt incinerator waste into inert glassy pebbles, valuable in concrete production. Incinerator ash has also been chemically separated into lye and other useful chemicals.

5.4 VOLUME REDUCTION

This means various techniques for making the waste fit into less space and easier to handle in bulk. The best way to reduce waste is not to dump it in the first place. The volume of produced waste can be reduced by mechanical compaction or fragmentation. In practice, the terms shredding, grinding, and milling are used interchangeably to describe mechanical size reduction. The objective of size reduction is to obtain a final product that is reasonably uniform and considerably reduced in size in comparison with its original form to help comfortable and safe transportation.

5.5 COMPACTION

The waste is compacted or compressed. It also breaks up large or fragile items of waste. This process is conspicuous in the feed at the back end of many garbage collection vehicles. See car crusher in landfill sites, the waste is often compacted by driving over it a heavy excavator-type vehicle with spiked wheels

5.6 SHEARING

The waste is sliced with heavy metal shears.

5.7 CLIPPING

The waste is sliced with heavy metal shears.

5.8 GRINDING

The waste is ground up hammer mill.

5.9 RESOURCE RECOVERY TECHNIQUES

A relatively recent idea in waste management has been to treat the waste material as a resource to be exploited, instead of simply a challenge to be managed and disposed of. There are a number of different methods by which resources may be extracted from waste: the materials may be extracted and recycled, or the calorific content of the waste may be converted to electricity. The process of extracting resources or value from waste is variously referred to as secondary resource recovery, recycling, and other terms. The practice of treating waste materials as a resource is becoming more common, especially in metropolitan areas where space for new landfills is becoming scarcer. There is also a growing acknowledgement that simply disposing of waste materials is unsustainable in the long term, as there is a finite supply of most raw materials. There are a number of methods of recovering resources from waste materials, with new technologies and methods being developed continuously.

5.10 REUSE

Everything can be reused therefore used items should not just be thrown away after use if they are reusable. In this way there will be significant reduction in waste and better conservation of resources. Normally items, which can be re-used, include plastic jerry cans, oil cans, metal cans, glass jars, bottles, and jute and cotton sacs.

5.11 RECYCLING

Through resource mobilization and by raising awareness among the citizen, useless things which are generated as solid waste are generally converted into useful items and energy. Almost 20-30 per cent of MSW contains materials which could be recycled. For example, paper can be re-pulped and reprocessed into recycled paper, cardboard and other paper products. Broken glasses can be crushed, re-melted and made as containers. Plastic wastes can be re-melted and fabricated into carpet fiber or cloth. Food wastes and yard wastes can be composted to produce fertilizers and soil conditioners.

Recycling systems are often well established in Asian cities. Recycling does occur informally to some extent in Gilgit. Glass, plastic and metals are separated at source and sold to waste

contractors, who take the materials down country for processing. This provides a small supplementary income for Gilgit poorer household.

5.12 COMPOSTING AND DIGESTION

Waste materials that are organic in nature, such as food scraps and paper products, are increasingly being recycled. These materials are put through a composting or artificial digestion process to decompose the organic matter and kill pathogens. The organic material is then recycled as mulch or compost for agricultural or landscaping purposes. There are a large variety of composting methods and technologies, varying in complexity from simple window composting of shredded plant material, to automated enclosed-vessel digestion of mixed domestic waste. Composting methods can be broadly categorized into aerobic or anaerobic methods, although hybrids of the two methods also exist

5.13 INCINERATION, PARALYSIS AND GASIFICATION

Use of incinerators for waste management is controversial, and most Americans passionately oppose it. This controversy roots from the understandable conflict between short-term concerns and long-term ones, in this case between burning the wastes now, or postponing this problem by passing the waste burden to future generations. Whether any form of incineration or thermal treatment should be defined as "resource recovery" is a matter of dispute in policy-making circles. Paralysis and Gasification are two related forms of thermal treatment where materials are incinerated with limited oxygen. The process typically occurs in a sealed vessel, under high temperature and pressure. Converting material to energy this way is more efficient than direct incineration, with more energy able to be recovered and used. Paralysis of solid waste converts the material into solid, liquid and gas products. The liquid oil and gas can be burnt to produce energy or refined into other products. The solid residue (char) can be further refined into products such as carbon. Gasification is used to convert organic materials directly into a synthetic gas composed of carbon monoxide and hydrogen. The gas is then burnt to produce electricity and steam. Gasification is used in biomass power stations to produce renewable energy and heat.

REFERENCES

Arshad Ali, HashimNisarHashmi, HabibAkber (2010),Hydro Nepal: Journal of Water, Energy and Environment ISSN 1998-5452

Abu Qdais H.A. (2006), Techno-economic assessment of municipal solid waste management in Jordan. Waste Management (article in press).

Allende, R., (2009). Waste history in the Gambia.Thesis (MSC).University of the Gambia.

Buenrostro, O. Bocco, G. & Cram, S. (2001). Classification of sources of municipal solid wastes in developing countries.Resor. Cons. Recycl. 32: 29-41.

C. Visvanathan, J. Trankler, P. Kuruparan, B.F.A Basnayake, C. Chiemchaisri, J. Kurian&Z. Gonming Proceedings Sardinia 2005, Tenth International Waste Management and Landfill Symposium S. Margherita di Pula, Cagliari, Italy; 3 - 7 October 2005.

Dhere, M.A., Chandrasekhar, B. P., Pratapsingh, B. P. &Dhanraj, A. P. (2008).Municipal solid waste disposal in Pune city- An analysis of air and groundwater pollution. 95 (6): 773-777.

Daskalopoulos E., Badr O., Probert S.D. (1999), Economic and Environmental Evaluations of Waste Treatment and Disposal Technologies for Municipal Solid Waste. Applied Ecology 58, pp.2009-255.

Chandra, Y. I & Devi, N.L. (2009).Studies on Municipal Solid Waste Management in Mysore City- A case study.Report and Opinion. 2009; 1(3):15-21]. (ISSN: 1553-9873).

Kaushik, S. &Joshi,.B.D (2011), Comparative Study of Solid Waste Generation at Mansa Devi and Chandi Devi Temples in the Shiwalik Foothills, during the KumbhMela 2010.

Mahar, A. Malik, R.N. Ahmed, T. Khan, Z. & Khan, M.A. (2007).Proceedings of the International Conference on Sustainable Solid Waste Management, 5 - 7 September 2007, Chennai, India. Pp.34-41

Omofonmwan, S. I. &Eseigbe, J. O. (2009).Effect of solid waste on the quality of underground water in Benin Metropolis, Nigeria. J. Hum. Ecol. 26(2): 99-105.

Pak-EPA, Guidelines for Solid Waste Management, Pak-EPA in collaboration with JICA, Ministry of Environment, PEP and UNDP (2005).

Ranaweera, R.M.R.P. and Trankler, J. (2001), "Pre-Treatment Prior Final Disposal -A Case Study for Thailand" In Proceedings Sardinia, Eighth International Waste management andLandfill Symposium, Pula, Cagliari, Italy, Vol III, pp.187-196.

Sharma, V., Saini, P. & Joshi, B. D. (2010). Assessment of municipal solid waste generation and its management in the holy city of Haridwar, Uttarakhand State, India. *Wast. Manage.* 30: 725-728.

Schubeler, P., (1996). UNDP/UNCHS (Habitat)/World Bank/SDC Collaborative Programme on Municipal Solid Waste management in Low-Income Countries. *Urban management and Infrastructure. Conceptual Framework for Municipal Solid Waste Management in Low-Income Countries. Working Paper No. 9.* Available from [http://science.jrank.org/pages/7297/Waste- Management.html](http://science.jrank.org/pages/7297/Waste-Management.html) [Accessed 20 December 2011].

Visvanathan, C. Tubtimthai, O. and Kuruparan P.(2004), Influence of Landfill Top Cover Design on Methane Oxidation: Pilot Scale Lysimeter Experiments under Tropical Conditions, 3rd Asia Pacific Landfill Symposium, Kitakyushu, Japan, Oct 27-29.

World Bank (1999), "What a waste - Solid waste management in Asia" *Urban and Local Government Working Papers*, The International Bank for Reconstruction and Development/THE WORLD BANK, 1818 H Street, N.W. Washington, D.C. 20433, U.S.A.

Yahaya, S., Ilori, C. Whanda, S. & Edicha, J. (2010). Land Fill Site Selection for Municipal Solid Waste Management using Geographic Information System and Multi criteria Evaluation. *American Journal of Scientific Research* ISSN 1450-223X Issue 10 (2010), pp. 34-49



Gilgit-Baltistan Environmental Protection Agency

GB-EPA Khomar Cant near FPSC Office, Gilgit

Phone No. 05811-920679 Fax No. 05811-920676